



EASY SHAKE

Residential Metal Roofing Installation Guide

73000 AIRPORT LINE
R.R.2, BOX 137
HENSALL, ONTARIO
N0M 1X0



TEL. : 519-263-3107
TOLL FREE : 1-888-763-7779
FAX: 519-263-3108
EMAIL : easybp@tcc.on.ca

www.easybuildingproducts.ca

JANUARY 2023

IMPORTANT NOTICE

Upon delivery: check the packing slip to ensure all goods have arrived and are in good condition. The panels must be installed within 6 months from the date they reach the designated job site.

The recommended installation procedures in this guide are meant to assist you in properly installing a metal roof on your home. The recommended application details are for illustrative purposes only and may not be deemed appropriate for all building designs and environmental conditions. Always consult your local building codes and regulations before installation.

The contents of this manual include the guidelines that were in effect at the time this publication was originally printed. In an effort to keep pace with the ever-changing code environment, Easy Building Products retains the right to change specifications and designs at any time without incurring any obligations. For the most up to date information please inquire within or check our website.

Proper Storage

Indoor Storage: Plain and prepainted galvanized/ galvalume roofing and siding panels are best kept under a roof in a cool, dry, well-ventilated area. To avoid condensation when storing indoors, leave the panels on blocks uncovered for best air circulation.

Outdoor Storage: When storing outdoors place the panels on blocks for proper ventilation (use more blocks in the centre to prevent sagging). Slightly elevate one end for drainage. Cover for added protection from the elements. **DO NOT** use a tight fitting plastic-type tarp, as they tend to trap in heat and moisture which could accelerate corrosion.

If bundles get wet the panels must be set aside to dry separately.

Note: ACQ treated lumber is corrosive to steel products. **DO NOT** allow panel or flashing to come directly into contact with treated wood. Store away from material contaminants and aggressive chemicals i.e.; salt, fertilizers, oil, cement, grease, paint.

Proper Handling

Handling: To get the roof panels up onto your roof, place a ladder or two boards up against the fascia board sloping to the ground as far from the building as possible. Place the panel on the boards/ladder. With the help of another slowly pull the panel on to the roof. When handling individual panels, it is best to hang them from the edge seam. Support the full length of the panel as much as possible. **DO NOT** allow the roof panels to rub against each other.

Note: Exercise extreme caution when handling roofing panels on windy days.

Cutting Panels: For straight lines use a chalk line. Cutting is best done on the ground. **Never** use abrasive rotating blades to cut panels. The heat and sparks produced when using these saws could cause damage to the painted surface.

Walking on Panels: Avoid walking on panels whenever possible. If you must do so, wear clean rubber-soled shoes to avoid marking the surface and slipping off the roof.

Note: For the least chance of damage place your foot at the base of each step exactly where the strapping should lie.

Recommended Tools

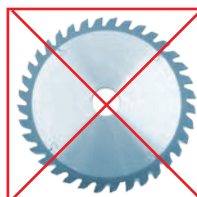

Any Rotating Blade /Angle Grinder

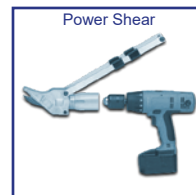

Strapping ONLY

Panel Installation

GLOSSARY/TERMS

Underlayment:	A material installed over the plywood sheathing prior to the installation of the roofing panel. Helps reduce condensation.
Strapping:	1"x 4" solid wood boards used to provide the fixing point for roofing panels. Nailed over top of the roofing underlayment on existing roofs.
Plywood Sheathing:	The base layer of material attached to the structural frame of the roof.
Chalk Line:	A tool for marking long, straight lines on relatively flat surfaces.
Eaves:	The projecting overhang at the lower edge of a roof.
Gable:	The generally triangular portion of a wall between the edges of a sloping roof.
Gable/Pitched Roof:	A roof sloping downward in two parts at an angle from a central ridge, so as to leave a gable at each end.
Gable/Eave Fascia Board:	A band running horizontally and situated vertically under the eaves/gable of the roof.
Flashing/Trim:	Sheet metal used to weatherproof the joints and angles of a roof.
Hip:	The outer angle portion where two sloped roof areas meet.
Cottage Hip Roof:	A roof where all sides slope downwards to the walls.
Ridge:	The line of intersection at the top between the opposite slopes or sides of a roof.
Ridge Cap:	The roofing material specifically purposed / manufactured for installation on the ridge.
Valley:	A depression or angle formed by the meeting of two inclined sides of a roof.
Dormer:	A gabled extension built out from a sloping roof to accommodate a vertical window.
Skylight:	A roof accessory used to add light, normally mounted on a curbed framed opening.

Legend

May require special attention:

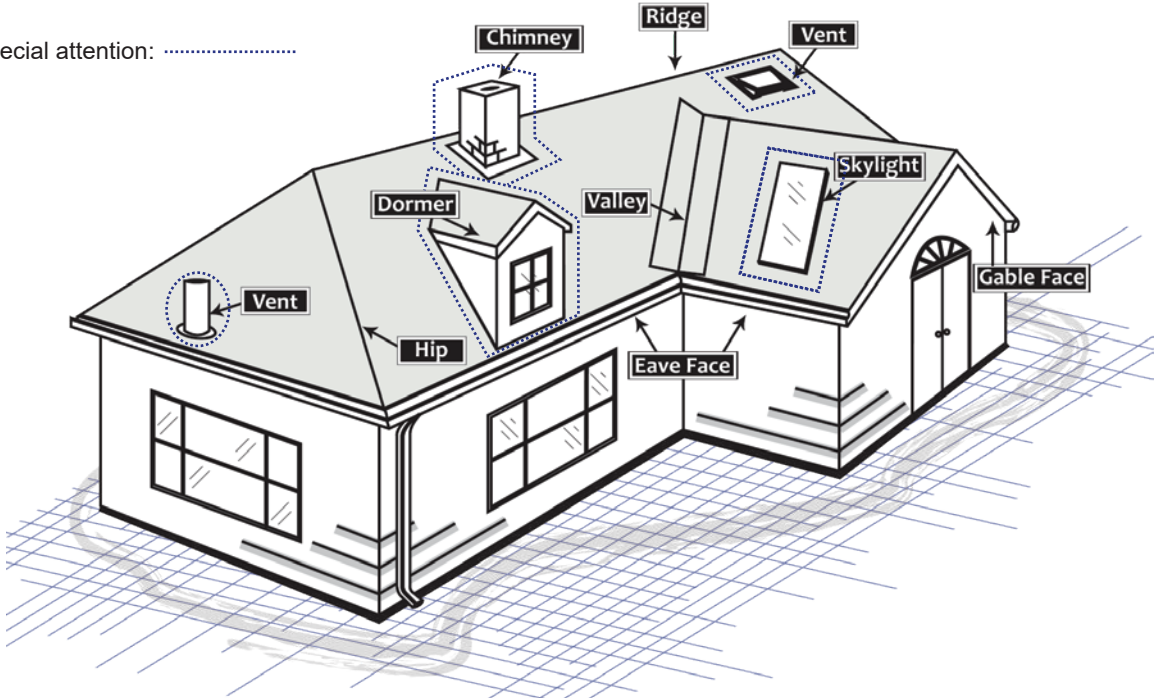

Steel panels may have sharp edges. Protective clothing and gloves should be utilized. To prevent eye injury, safety glasses must be worn when drilling or cutting steel panels. Use extreme care when walking on the roof panels. Steel panels become slippery when wet. Do not work on the steel panels when wet or when weather conditions are not suitable for safe installation.

PRE-INSTALLATION

*** Always follow local *
building codes**

Easy Shake Panels can be installed on 1" x 4" wood strapping with approved synthetic underlayment, 1/2" plywood with approved underlayment or directly to wood frame.

Re-roofing an existing roof? In most cases Easy Shake Panels can be installed right over top of your existing shingled roof (Figure 2.2). Trim all existing shingles flush with the fascia board. Inspect all joint locations and plywood condition. Then follow the installation options below.

Note: Screws should not hit joints between plywood sheets; this will reduce their holding power.

Installation options

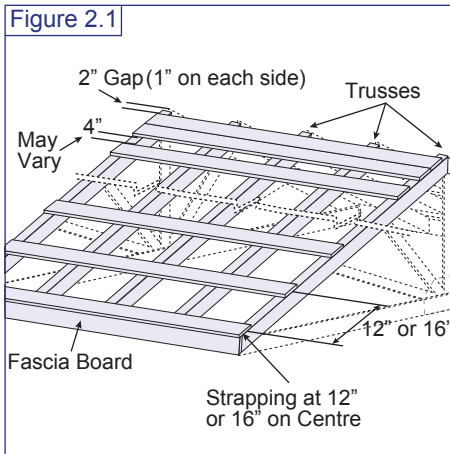

Install Panel Directly to Wood Frame

- ① Use maximum 16" strapping spacing (adjust according to step length)
- ② Install metal panel

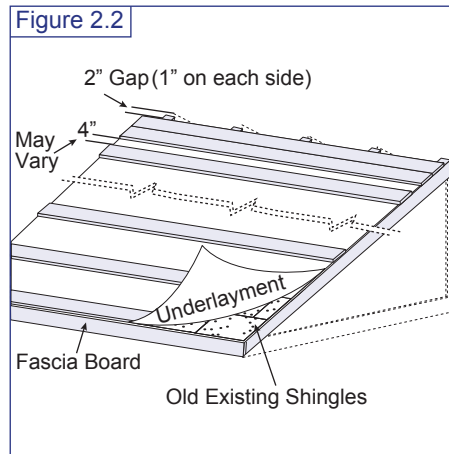

Install Panel Over Existing Shingles

- ① Apply synthetic underlayment
- ② Install 1"x4" wood strapping
- ③ Install metal panel

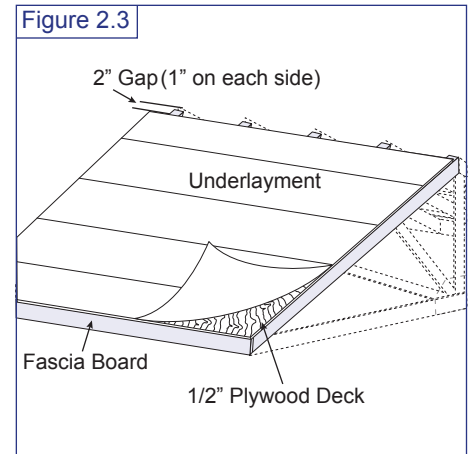

Install Panel on Solid Deck

- ① Lay plywood deck
- ② Apply synthetic underlayment
- ③ Install metal panel

Plywood Installation:

Install plywood on top of the roof framing. Be sure to leave a 2" gap at the ridge (Figure 2.3) for proper ventilation. In areas where ice and snow dams are possible install eave protection or underlayment. *Check with your local building code.

A Square Roof: (Figure 2.4)

Before installation it is crucial to check how square the roof is. Panels are installed at 90 degrees (right angle) to the eaves. At a corner where the gable and eave meet, measure six feet up the gable edge from the eave and make a mark. Then measure eight feet along the eave face and make another mark. Measure the distance between the two marks. If it measures out to be 10' exactly then you have a square roof. Check all roof corners using this method.

Correction:

If the panel deviation is minimal it can be corrected a small amount from panel to panel taking advantage of the tolerances in the panel. For more significant deviations, the panels along the gable can be trimmed along its length to match. A gable trim is used to cover up the un-even edge of a trimmed panel.

Strapping Installation:

Install underlayment on top of roof framing. Starting flush with the fascia board, install 1" x 4" strapping at 16" on centre (adjust according to step length). The last 1" x 4" should be 2" down from the ridge with a second 1" x 4" nailed right against it (Figure 2.1). Be sure to make a slit in the underlayment along the ridge line gap to allow for proper ventilation. Strap around all vent pipes. **Double up strapping at all valleys, hips and anticipated snow stop areas (Same as ridge (Figure 2.1, without 2" gap)).**

Note: Always make sure to adjust strapping according to step length

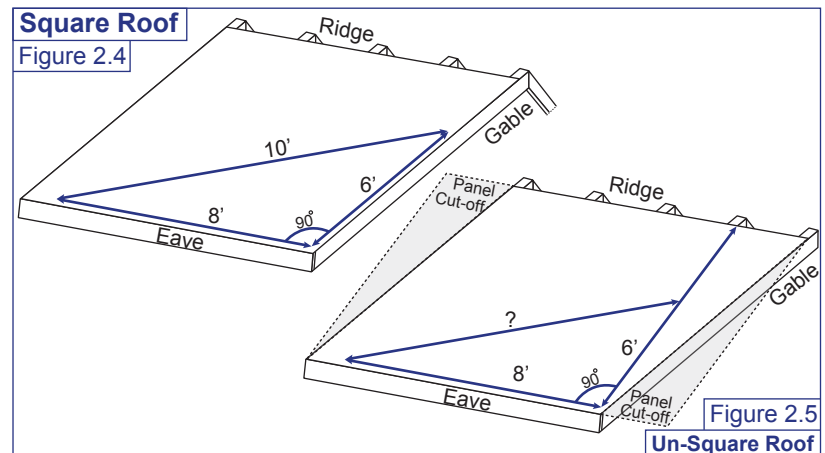

Note: Slopes of less than 3" on 12" (3/12 pitch) are not recommended.

INSTALLATION SEQUENCE

The example below is specific to installation option two, re-roofing **over existing shingles** (Page 3, Figure 2.2). The actual sequence may vary based on specific roof plan and conditions. Always follow local building codes.

Note: If installing Easy Shake on 1/2" plywood remember to install underlayment **above** the plywood (Page 3, Figure 2.3)

1 Underlayment + 1" x 4" Strapping

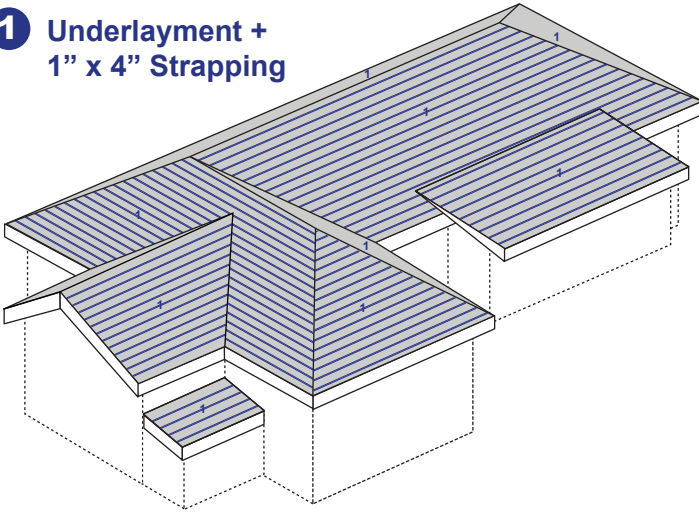

Install **Underlayment** as per manufacturer instructions.

2 Eave Trim

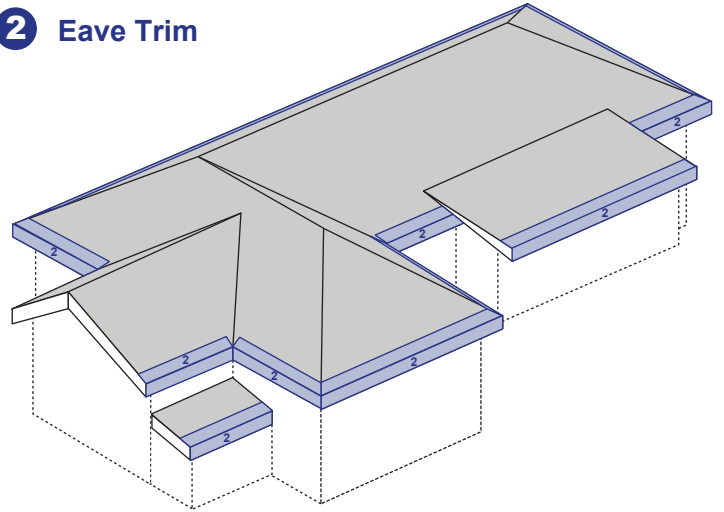

Install **Eave Trim** along all eaves (Figure 3.1, Page 6).

3 Under Pan

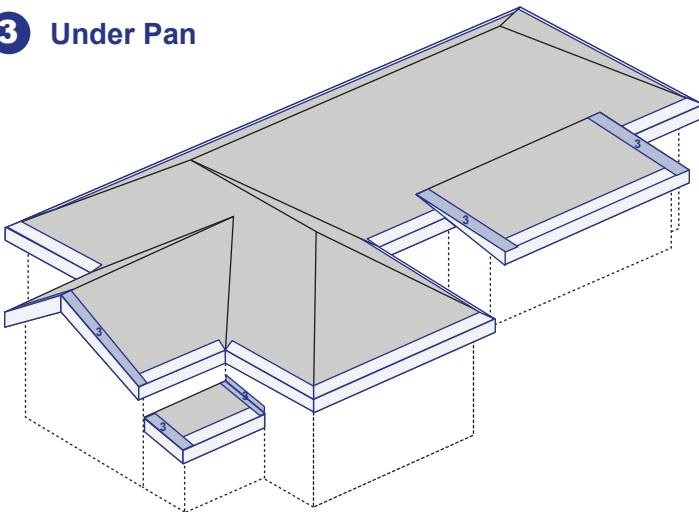

Install the **Under Pan** over all gable ends (Figure 4.1, Pg.6) and where End Wall Flashing (Figure 7.1, Pg.7) will be installed.

4 Valley Trim

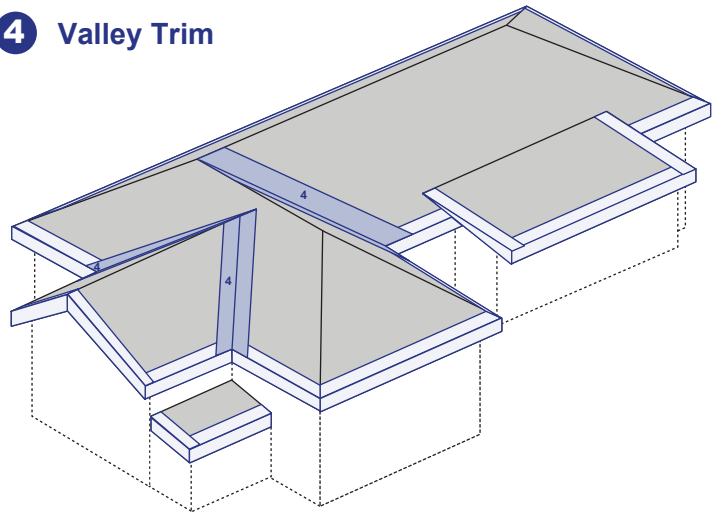

Install the **Valley Trim** over the Eave Trim starting from eave to the valley peak (Figure 5.1, Page 6).

5 Easy Shake Panel

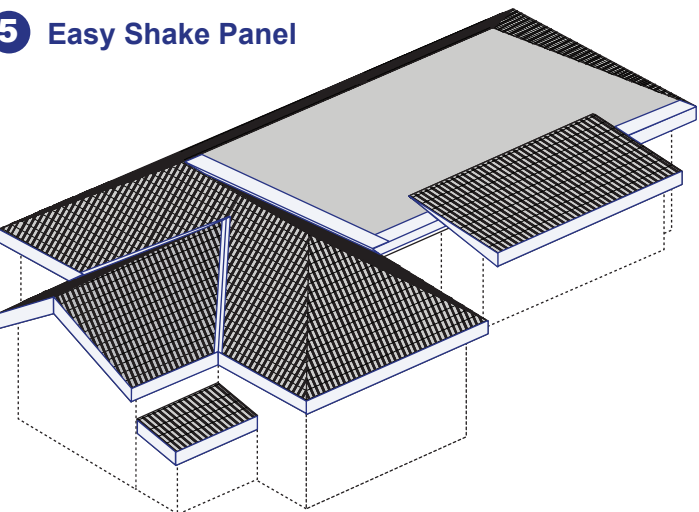

Install **Easy Shake Panels** over Eave Trims, Under Pan and Valley Trims. Do not install panels where the Reverse Hip laps under the panels.

6 Reverse Hip

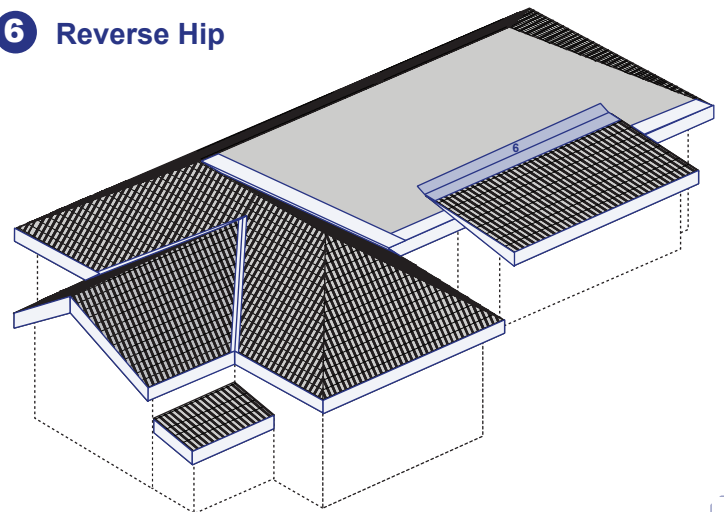

Install the **Reverse Hip** over the low slope panels and underlayment (Figure 6.1, Page 7).

INSTALLATION SEQUENCE

The example below is specific to installation option two, re-roofing **over existing shingles** (Page 3, Figure 2.2). The actual sequence may vary based on specific roof plan and conditions. Always follow local building codes.

7 Easy Shake Panel

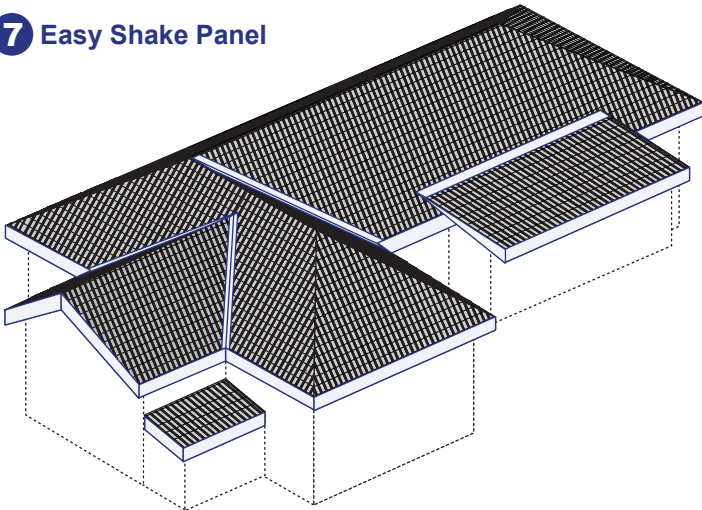

Finish **panel** installation. Install high slope **panels** over Transition Trim and any remaining exposed areas.

8 Side Wall/ End Wall Trim

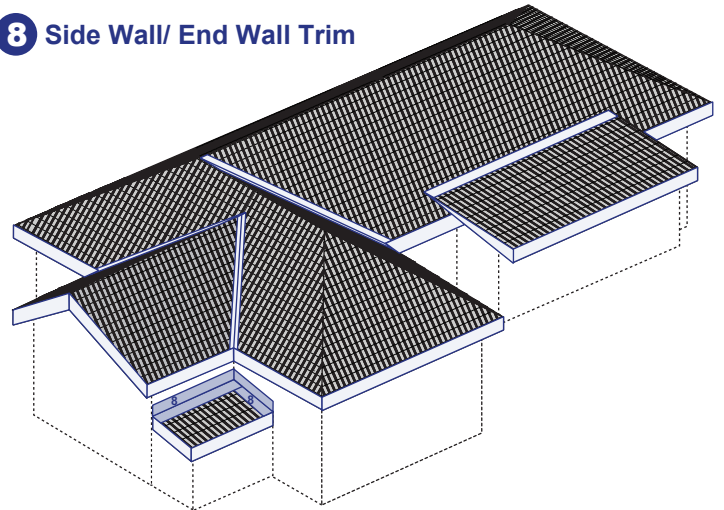

Install **Side Wall** and **End Wall** Trim over panels (Figures 7.2, Page 7).

9 Gable Cover

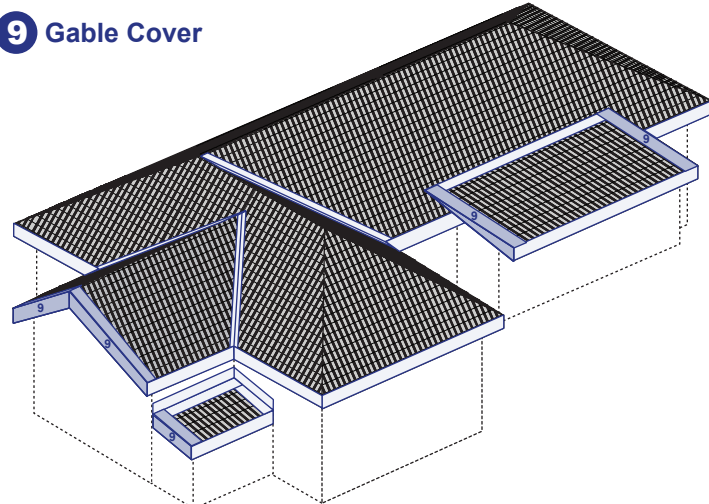

Install **Gable Cover** along all gable ends on top of panels (Figures 4.2, Page 6).

10 Hip Trim

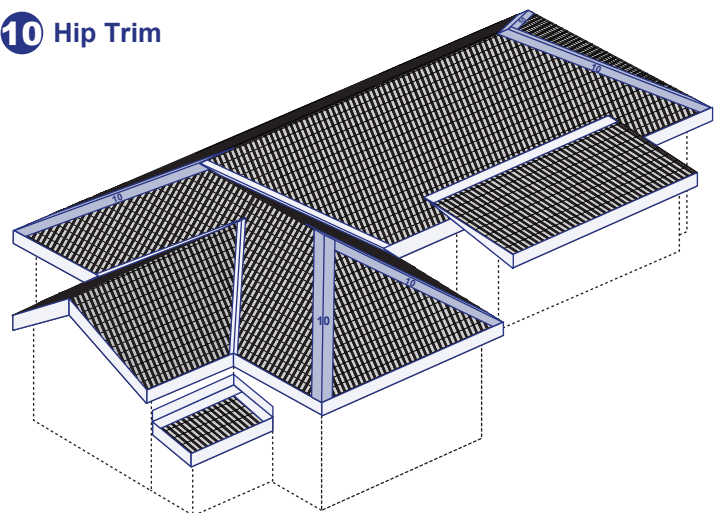

Install **Hip Trim** over panels (Figure 8.1, Page 7).

11 Ridge Cap

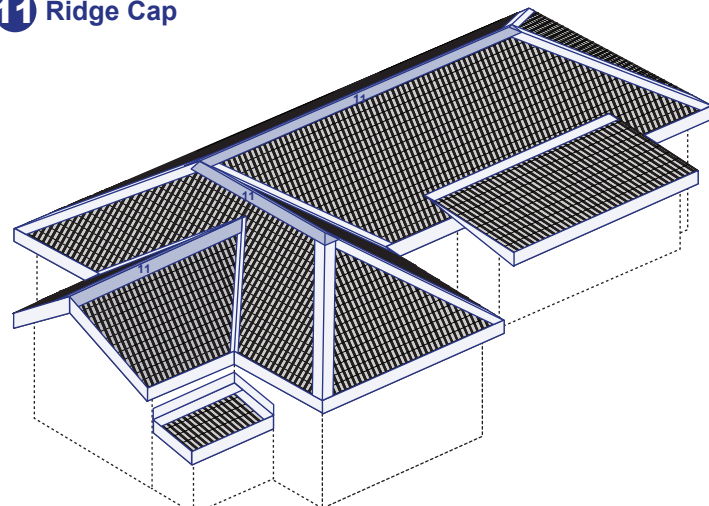

Install **Ridge Cap** over panels (Figure 8.1, Page 7).

TRIM INSTALLATION

* Custom Trims Available *

This example is specific to installation option two, re-roofing **over existing shingles** (Page 3, Figure 2.2). The actual sequence may vary based on specific roof plan and conditions. Always follow local building codes. Numbers indicate suggested trim assembly sequence.

Phase One - Pre Panel Installation

Phase Two - Panel Installation

Eave Trim:

Figure 3.1

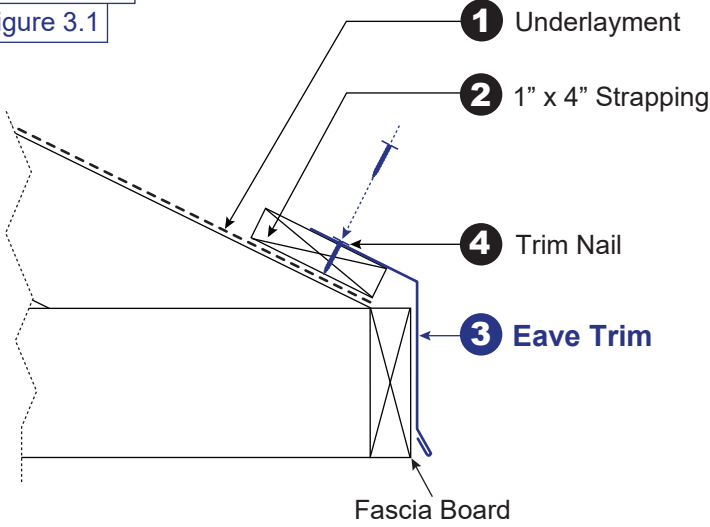

Eave Trim:

Figure 3.2

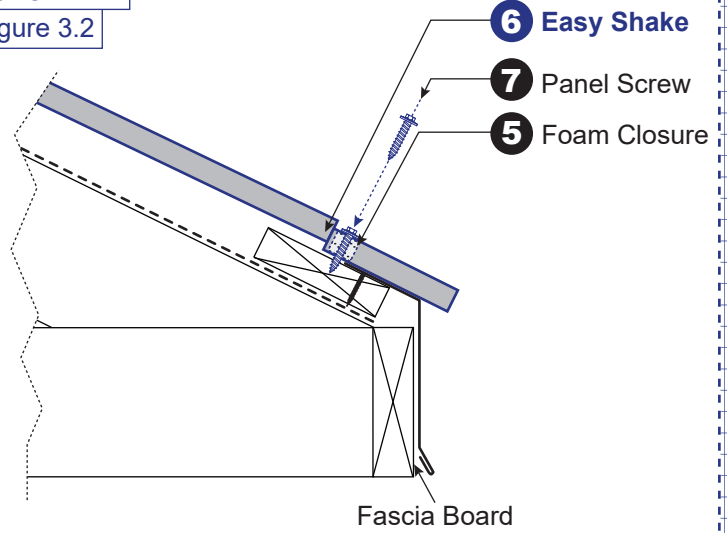

Gable Underpan:

Figure 4.1

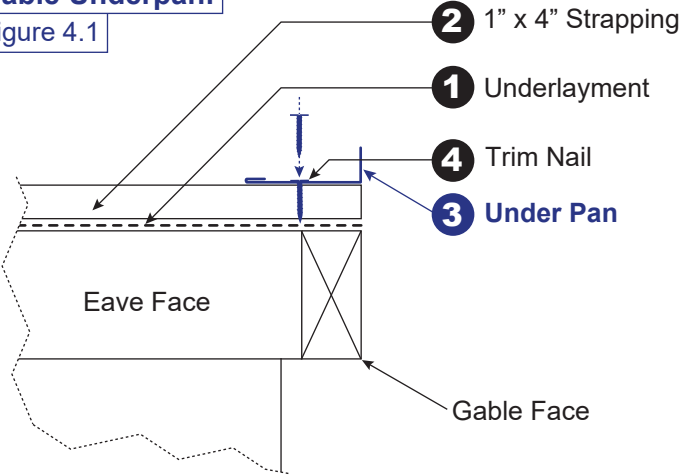

Gable Cover:

Figure 4.2

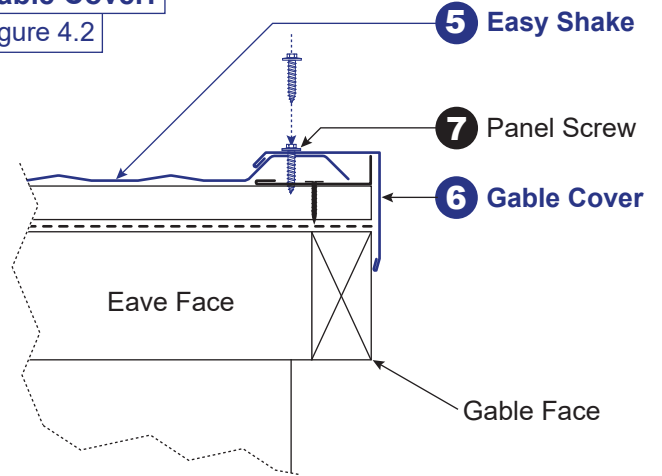

Valley Flashing:

Figure 5.1

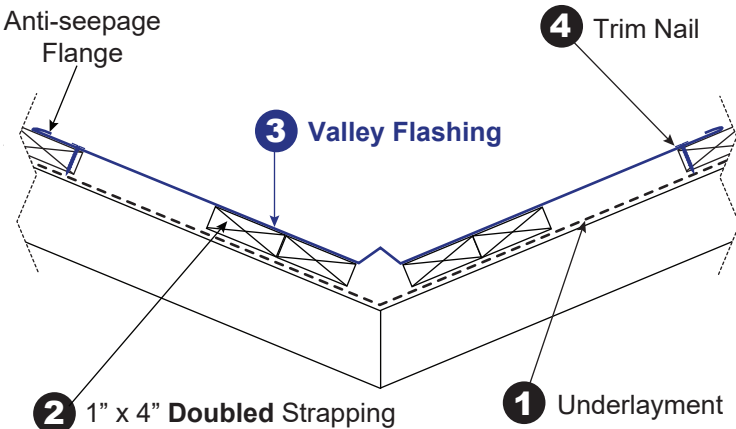

Valley Flashing:

Figure 5.2

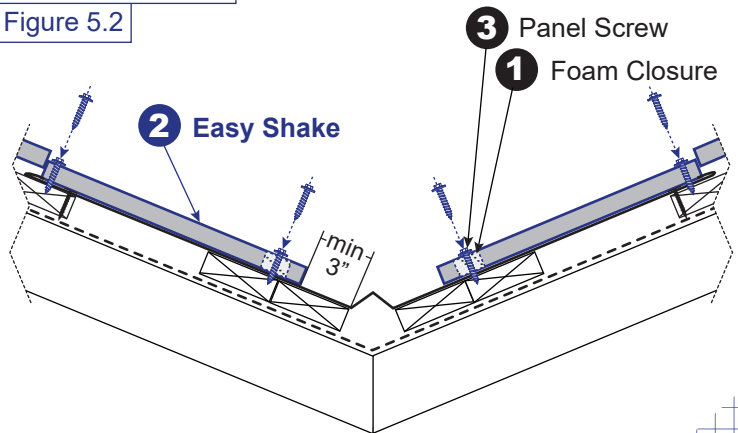

TRIM INSTALLATION

This example is specific to installation option two, re-roofing **over existing shingles** (Page 3, Figure 2.2). The actual sequence may vary based on specific roof plan and conditions. Always follow local building codes. Numbers indicate suggested trim assembly sequence.

Phase One - Pre Panel Installation

Phase Two - Panel Installation

Reverse Hip

Figure 6.1

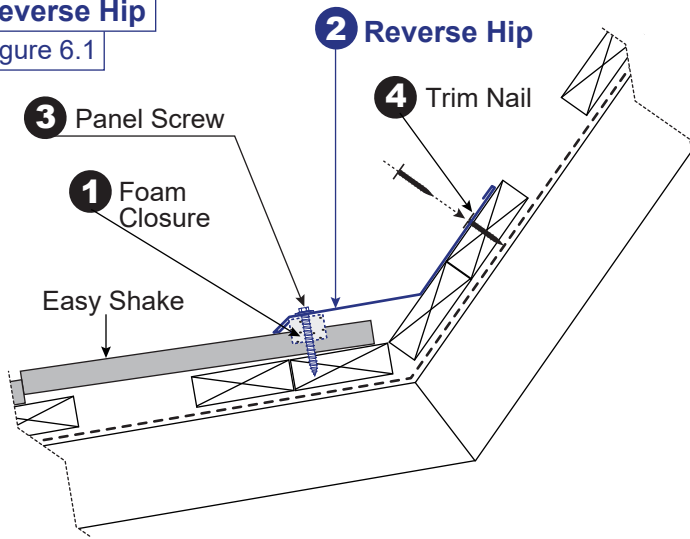

Reverse Hip

Figure 6.2

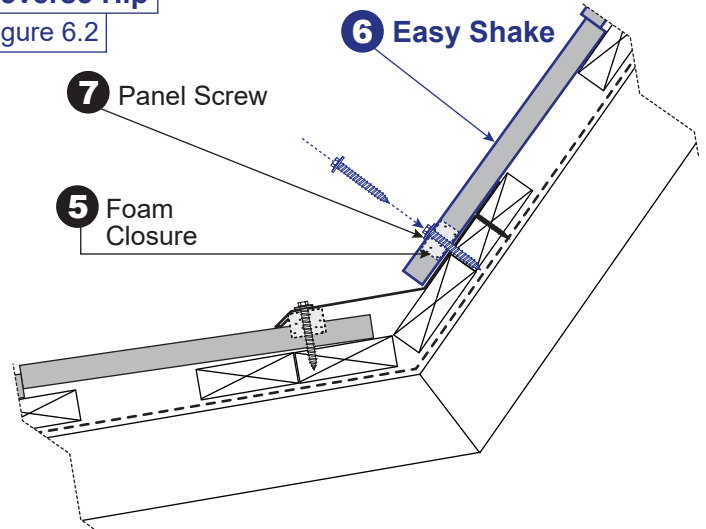

Under Pan For Wall Flashing

Figure 7.1

The Under Pan is not used with Side Wall Flashing

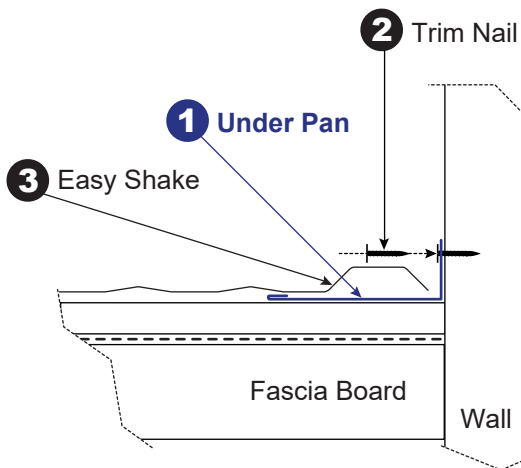

End Wall Flashing (90°) Side Wall Flashing (Bent to Pitch)

Figure 7.2

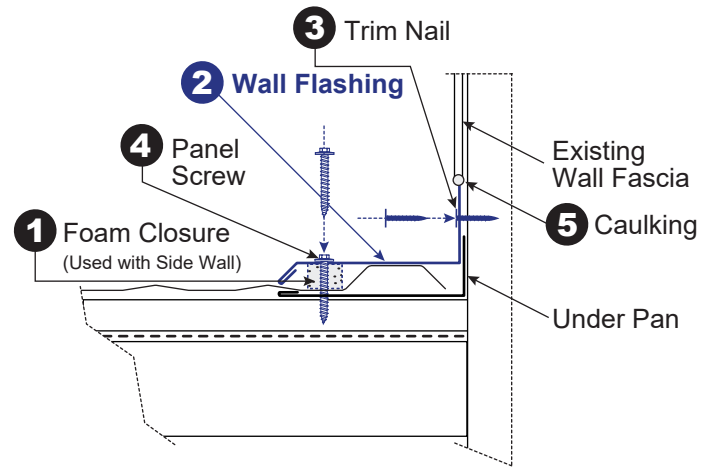

Ridge Cap

Figure 8.1

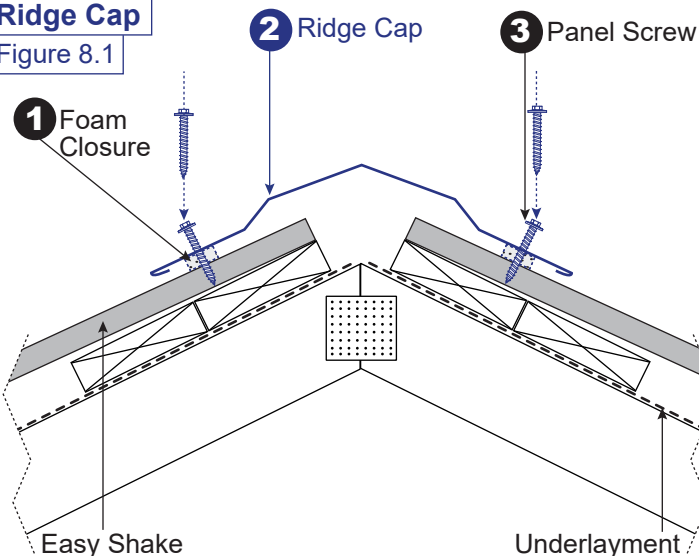

Ridge/ Hip Cap

Figure 8.2

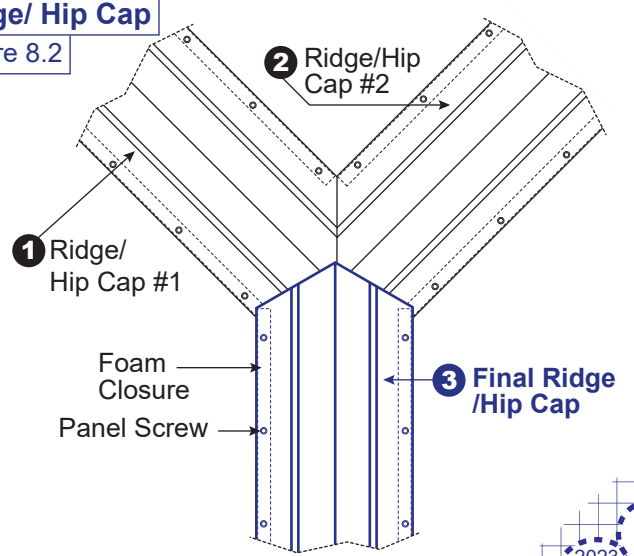

PANEL INSTALLATION

Getting Started:

Upon acceptance of your Easy Shake order, a layout of the roof will be provided with each section marked A, B, C etc... and a starting point marked with an arrow showing the direction to lay the roofing panels. The quantities and lengths of panels will be on the packing slip provided.

All sections of your roof will be bundled as one (depending on size of order). Each section within will be marked A,B,C etc... to coincide with the roof layout and the packing slip.

Placement: (Figure 9.1)

Install EASY Shake from right to left. Begin at the gable ends (most cases, depending on roof design), then hips and **always towards valleys**. Maintain an overhang of 1" at the eave.

Alignment: (Page 3, Figure 2.4)

It is important to start installation of EASY Shake square to the eave (Page 3, Figure 2.4). As you move along double check the panel alignment every three rows by making a chalk line square to the eave.

Lapping: (Figure 9.1)

Place the panels one at a time from the eave to the ridge before starting with the next row (Figure 9.1). Overlapping panels should be done along the strapping for proper support. For most buildings a single panel will cover from eave to ridge, not requiring any overlaps. If required, overlap panels by one step.

Note: In certain scenarios it may be necessary to slip a panel underneath a partially fastened one rather than on top. If so, simply lift the unfastened edge of the partially fastened panel and slip the next one underneath.

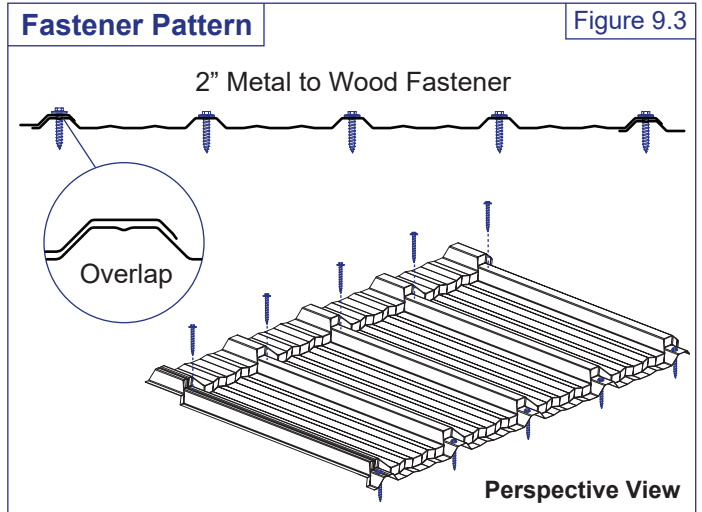
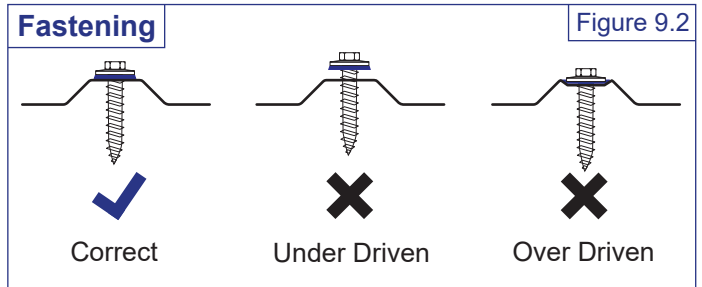

Fastening: (Figure 9.2 - 9.3)

Avoid damaging the roofing panel and washers by over tightening. Place the 2" fasteners along the base of each step on each and every large rib across the panel width. (Figure 9.3)

Note: **DO NOT** fasten the seam/open side of the panel before starting with your next panel.

Note: **DO NOT** install fasteners along the ridge until you have properly installed the ridge cap. Remember to fasten through the ridge cap, foam closure and roofing panel.

Note: Remove any left-over fasteners, burrs and filings. Leaving particles could cause them to rust and stain.

Cottage Hip Roofs: (Figure 9.4)

Start with 2 panels in the middle of the hip section. The overlapped rib should be centered with the peak. From this point continue working towards the edges of the roof.

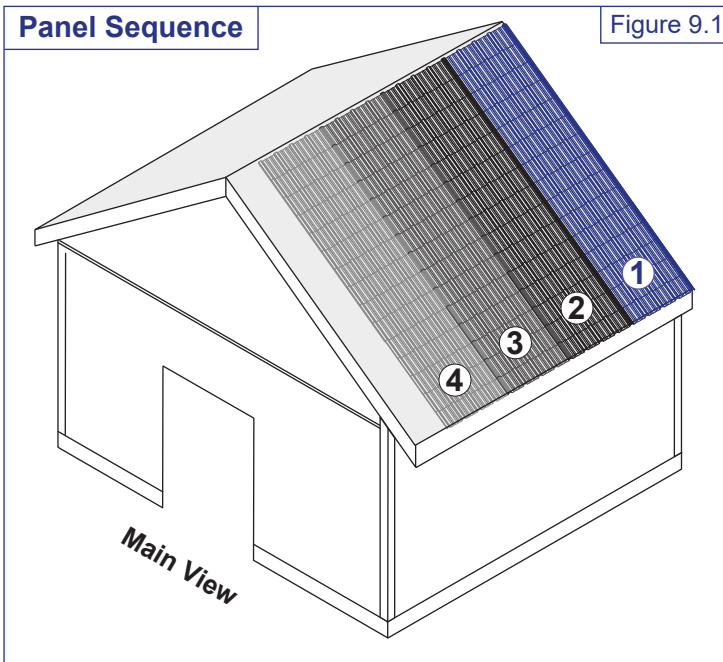
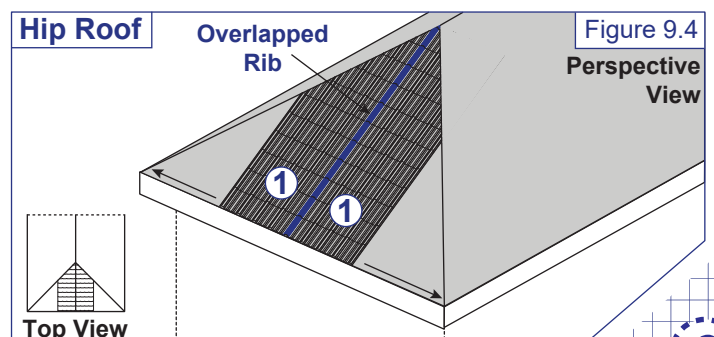

TRIM INSTALLATION

Valley Flashing: (Figure 5.1, Page 6)

Begin by placing the valley flashing from the base of the valley. Apply pressure to allow the flashing to conform to the valley. Apply pressure to allow the flashing to conform to the roof slope. Nail the sides of the flashing to the 1/2" plywood or 1" x 4" strapping. Place nails as far away from the centre as possible.

DO NOT cut the base of the valley flashing to form to the eaves. Leave a 1 1/2" overhang in the centre to form to the eave. Taper it back to 1/2" at 4" over, then 1/2" for the rest.

When overlapping valley flashing, overlap approximately 12". When dealing with a low-slope roof be sure to give extra overlap. Apply the next valley flashing on top with sealant between the flashing.

Dormers:

At the top of the valley flashing, draw a line on the valley flashing along the dormer ridge. Cut 2" over that line (Figure 10.1). Fold the valley flashing along the ridge line and nail it down. Do the same for the second flashing using a sealant between the overlapping flashings.

Dormer Valley - Panel Install: (Figures 10.1 - 10.3)

The idea here is to have the roofing panel notched out in a way that allows for the valley flashing to be above the panel on the bottom end and under the panel on the top end. Make a similar notch in the panel as seen in Figure 10.3. Make a 4" cut just past the end of the notch. Slide the valley flashing through/under that cut. Be careful when cutting into the panel (if you go too far, you'll need some sealant to fill the cut). Apply a sealant to the valley flashing and the roofing panel (Figure 10.3).

Note: Some dormers may require **Side Wall and End Wall Flashing** (Figure 7.1 - 7.2, Page 7)

Ridge/Hip Cap: (Figure 8.1, Page 7)

To ensure a straight installation and proper location of the ridge cap, use a chalk line to mark both sides of the roof. Lay down the closure strip along the chalk line with the adhesive (make sure the closure is not placed too far under the capping). Next place the ridge cap on top. Fasten through the closure strip down into the roofing panel. Caulk the overlap section and place the next ridge cap on top (repeat as necessary). **Three way intersection:** (Figure 8.2, Page 7) Fit the first two caps together, then fit the third and final cap on top.

Note: When installing on a hip, always begin from the base of the hip.

Dormer Valley - Panel

Figure 10.3

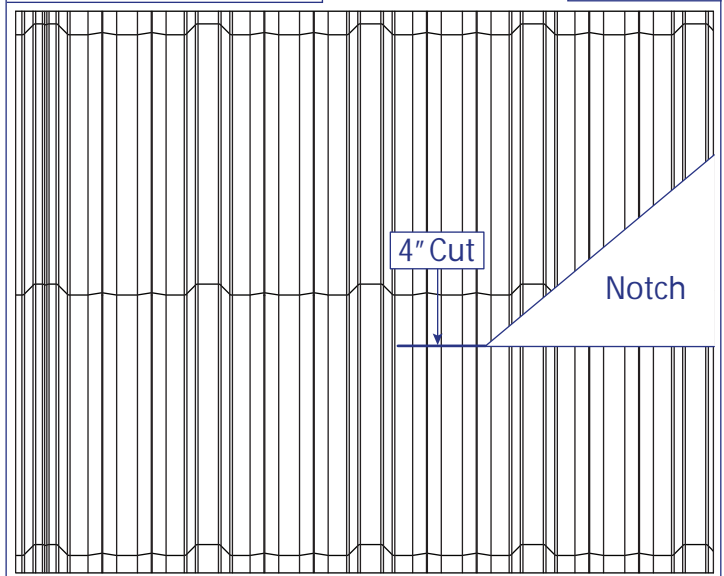

Dormer Flashing

Figure 10.1

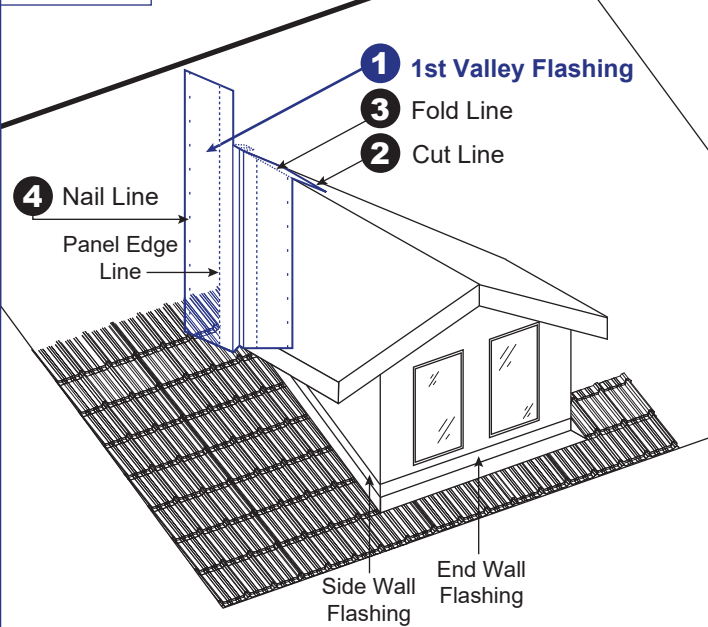

Dormer Flashing

Figure 10.2

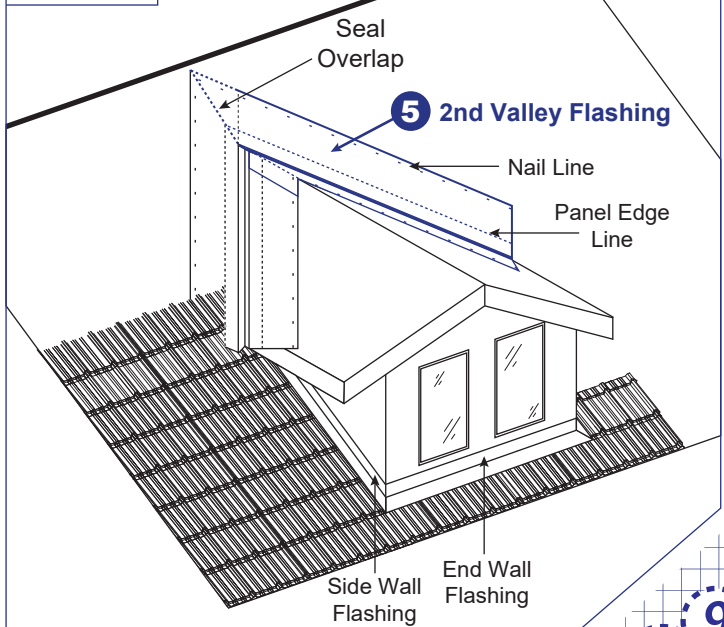

EXTRA INSTALLATIONS

Closures: (Figure 11.1)

Fasten straight through the closures to keep them in place. Foam closures are used under a variety of roof flashings (Page 6-7) and anywhere that driving rain and wind have the potential to get under the roofing panel. EASY Shake uses Enviro-Vent underneath the ridge cap.

Pipe Flashing: (Figure 11.2)

Pipe flashings are used around any pipe protruding from your roof i.e.; insulated steel chimney's, hydro stacks and vent pipes. Start by putting sealant between the flashing and the roof panel. Apply pressure to allow the flashing to conform to the roof panel. Screw the flashing down. Seal the edges with sealant.

Closures

Figure 11.1

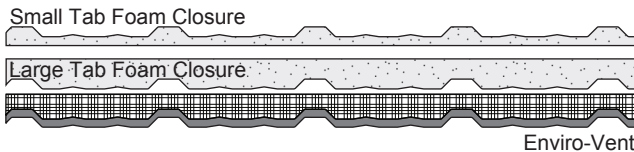

Pipe Flashing:

Figure 11.2

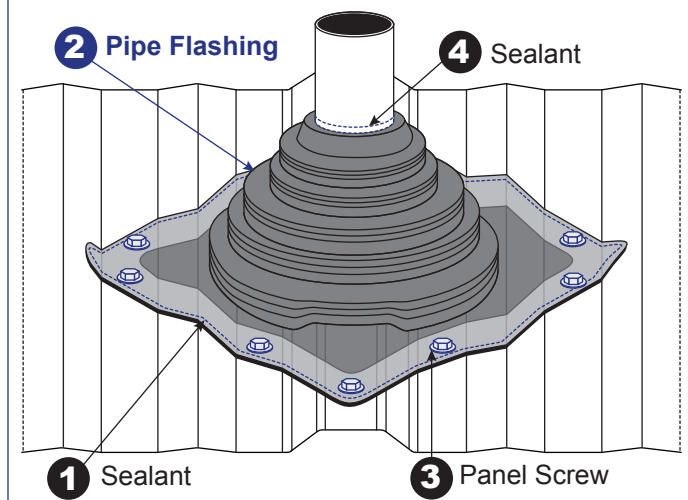

Side View

Figure 11.3

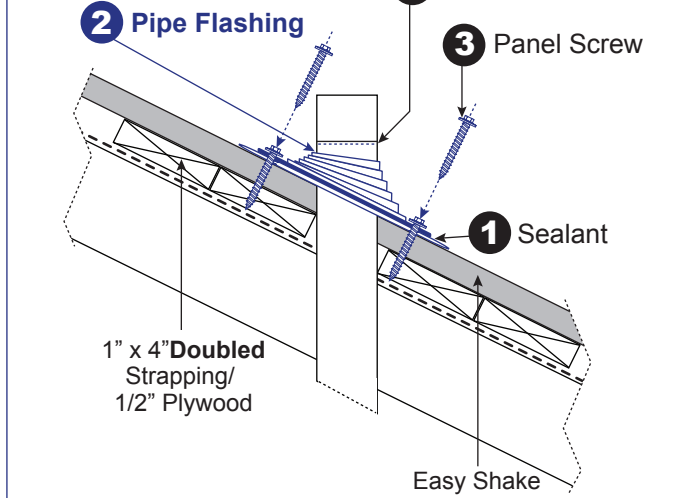

Snow Stop

Figure 11.4

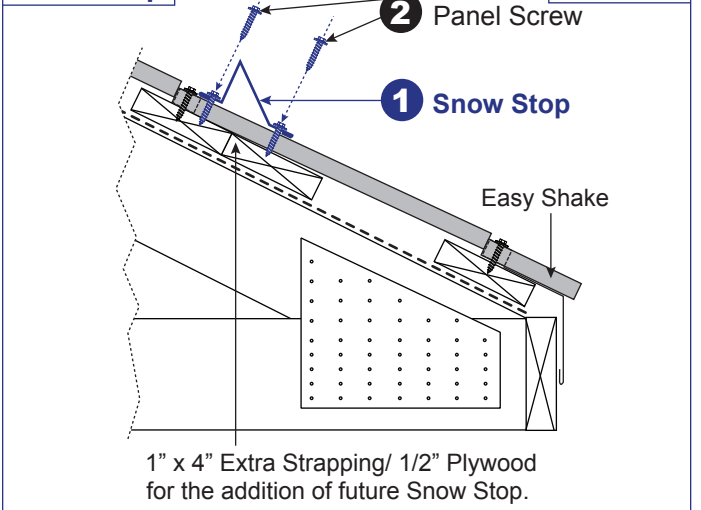

Snow Stop: (Figure 11.4)

These should be installed in areas where sliding snow and ice is a safety concern.

Skylight/Chimney: (Figure 11.5)

Skylights should be curb mounted on a 2" x 6" frame. Start with installing the bottom skylight/chimney flashing. Cut and bend the flashing around the corners of the skylight/chimney. Make sure to install a foam closure between the bottom flashing and the roofing panel. Next install the side flashings to overlap the lower flashing. Cut and bend the flashing same as before. Apply sealant at all overlaps. Install the final top flashing to go underneath of the roofing panel but on top of the side flashings. Cut, bend and seal the flashing same as before (Apply sealant between the top flashing and roofing panel).

Skylight/Chimney

Figure 11.5

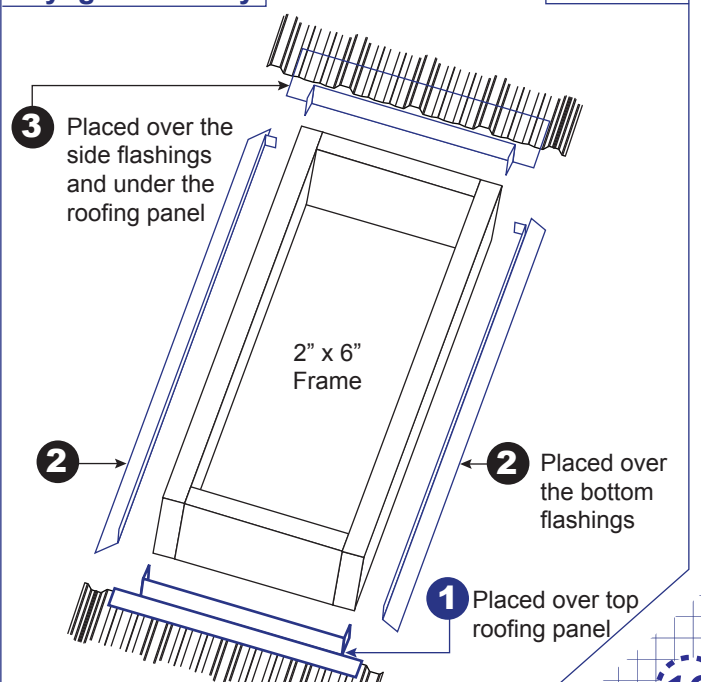

73000 AIRPORT LINE
R.R.2, BOX 137
HENSALL, ONTARIO
N0M 1X0



TEL. : 519-263-3107
TOLL FREE : 1-888-763-7779
FAX: 519-263-3108
EMAIL : easybp@tcc.on.ca

www.easybuildingproducts.ca

JANUARY 2023